

Magnescape®

Scale Unit

SR87, CH33 / CH34

Read all the instructions in the manual carefully before use and strictly follow them.
Keep the manual for future references.

Instruction Manual

[For U.S.A. and Canada]

THIS CLASS A DIGITAL DEVICE COMPLIES WITH PART 15 OF THE FCC RULES AND THE CANADIAN ICES-003. OPERATION IS SUBJECT TO THE FOLLOWING TWO CONDITIONS.

- (1) THIS DEVICE MAY NOT CAUSE HARMFUL INTERFERENCE, AND
- (2) THIS DEVICE MUST ACCEPT ANY INTERFERENCE RECEIVED, INCLUDING INTERFERENCE THAT MAY CAUSE UNDERSIGNED OPERATION.

CET APPAREIL NUMÉRIQUE DE LA CLASSE A EST CONFORME À LA NORME NMB-003 DU CANADA.

Safety Precautions

Magnescale Co., Ltd. products are designed in full consideration of safety. However, improper handling during operation or installation is dangerous and may lead to fire, electric shock or other accidents resulting in serious injury or death. In addition, these actions may also worsen machine performance.

Therefore, be sure to observe the following safety precautions in order to prevent these types of accidents, and to read these "Safety Precautions" before operating, installing, maintaining, inspecting, repairing or otherwise working on this unit.

Warning indication meanings

The following indications are used throughout this manual, and their contents should be understood before reading the text.

Warning

Failure to observe these precautions may lead to fire, electric shock or other accidents resulting in serious injury or death.

Caution

Failure to observe these precautions may lead to electric shock or other accidents resulting in injury or damage to surrounding objects.

Warning



- Do not use this unit with voltages other than the specified supply voltages as this may result in fire or electric shock.
- Do not perform installation work with wet hands as this may result in electric shock.



- Do not disassemble or modify the unit as this may result in injury or damage the internal circuits.

Caution



- Be sure to check the machine and device conditions to ensure work safety before working on the machine.



- Be sure to cut off the power supply and other sources of drive power before working on the machine. Failure to do so may result in fire or accidents.



- When turning on the power supply or other sources of drive power to operate the machine, take care not to catch your fingers in peripheral machines and devices.

General Precautions

When using Magnescale Co., Ltd. products, observe the following general precautions along with those given specifically in this manual to ensure proper use of the products.

- Before and during operations, be sure to check that our products function properly.
- Provide adequate safety measures to prevent damages in case our products should develop malfunctions.
- Use outside indicated specifications or purposes and modification of our products will void any warranty of the functions and performance as specified of our products.
- When using our products in combination with other equipment, the functions and performance as noted in this manual may not be attained, depending upon operating environmental conditions. Make full study of the compatibility in advance.

Contents

1. Overview	1
1-1. System Configuration	1
1-2. Features	1
2. Installation.....	2
2-1. Names of Parts	2
2-2. Installing the Scale and Slider	2
3. Scale (SR87) and Connection Cable	8
3-1. Scale (SR87)	8
3-1-1. Output Signal.....	8
3-1-2. Power Supply	8
3-2. Connection Cable (CH33 / CH34).....	9
3-2-1. CH33 / CH34 Signal Specifications.....	9
4. Air Purge	10
5. Specifications	13
5-1. Scale	13
5-2. Connection Cables	14
5-3. Accessories.....	14
6. Dimensional Diagrams	15

1. Overview

This product is a scale system that outputs position signals for machine tools and other equipment that require high-precision positioning.

1-1. System Configuration

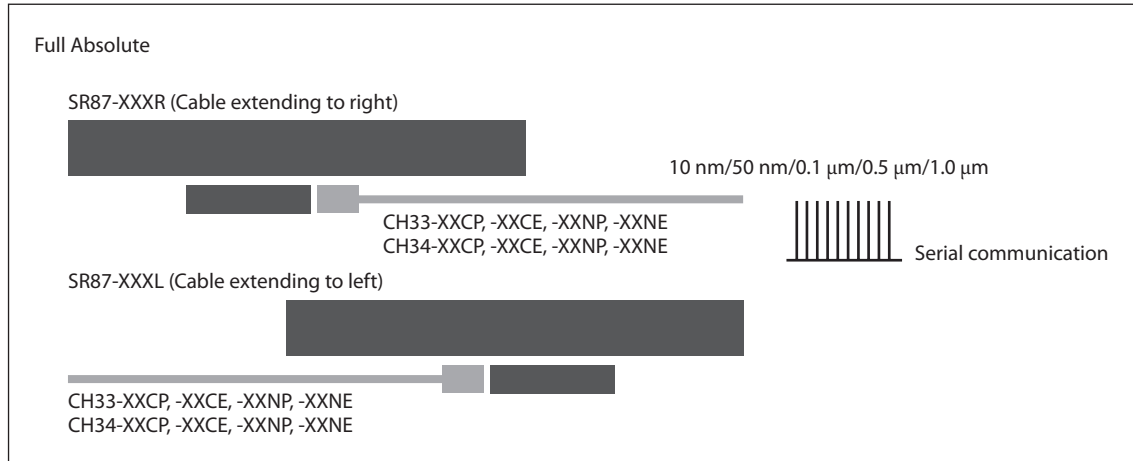

Fig. 1-1

Model name	Product name	Description	Remarks
SR87-XXX	MAGNESCALE (Full Absolute)	Serial communication signal output	XXX: Effective length (cm)
CH33-XXCP CH34-XXCP	Connection cable	Cable sheath: PVC With cable armor	XX: Cable length (m)
CH33-XXCE CH34-XXCE	Connection cable	Cable sheath: Polyurethane With cable armor	
CH33-XXNP CH34-XXNP	Connection cable	Cable sheath: PVC Without cable armor	
CH33-XXNE CH34-XXNE	Connection cable	Cable sheath: Polyurethane Without cable armor	

1-2. Features

- Steel bars are used for the scale case to achieve a high rigidity.
- The scale and connection cables are separated by the connector on the scale slider unit for easy installation.
- Includes a built-in function for correcting variations in scale signal levels for enabling high-precision positioning. High-precision correction function developed exclusively by Magnescale Co., Ltd. is used to realize high precision and high resolution.
- If the CH34 is used, scale signals can be checked* after installing the scale.

*: A signal checker (sold separately) is required for checking scale signals.

2. Installation

For the installation dimensions, refer to section 6, “Dimensional Diagrams.”

2-1. Names of Parts

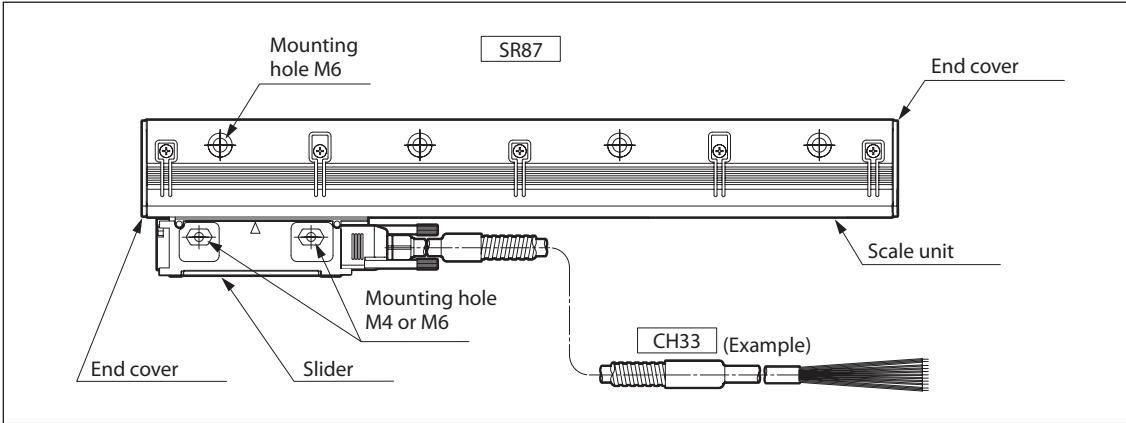

2-2. Installing the Scale and Slider

Notes

- Do not turn on the power before installing the scale.
- Install the scale with the opening on the scale unit facing downward. If the opening cannot be turned downward, it should face horizontally. Never install it facing upward. (Fig. 2-1)

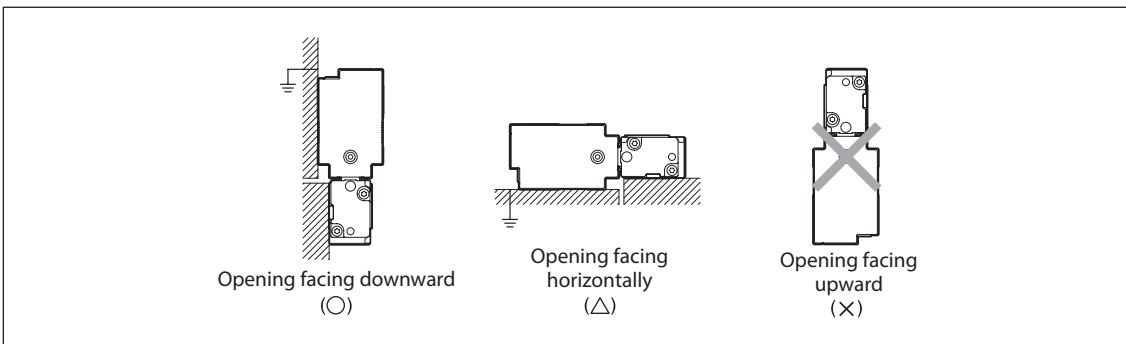

Fig. 2-1

- Remove off the coating around the tap hole to ground the scale unit using the installation surface contact with the scale.
- Be aware that the scale will be damaged if the slider is moved outside the effective length (L).
- In environments where coolant can splash directly on the scale, be sure to mount a cover on the scale to protect the scale from splashing. (Fig. 2-2)

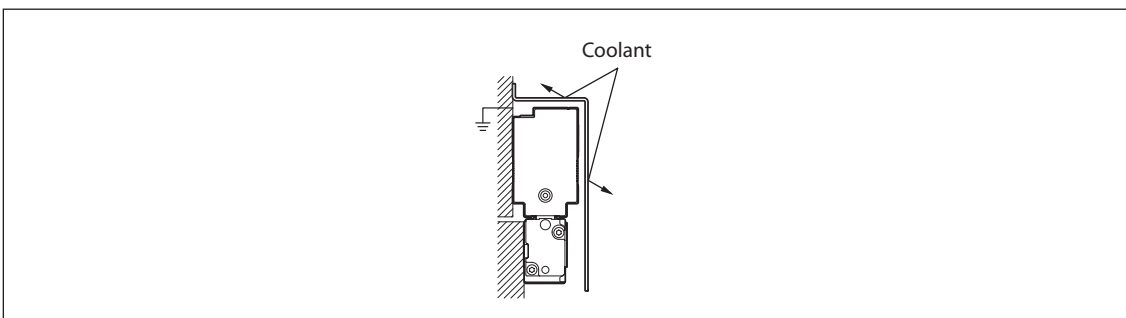

Fig. 2-2

- The slider holders are used to secure the slider in place during transport. They are not guides for installation.
- Do not take off the slider holders, if possible, until immediately before securing the slider.
 - Even if the slider holders are removed, the plastic hook provided on the slider allows the slider to maintain an approximate positional relationship with the scale unit.
 - The plastic hook can come off if the slider is forcibly twisted or other excessive force is applied. If the plastic hook comes off, return the plastic hook back to its original position before performing the installation.

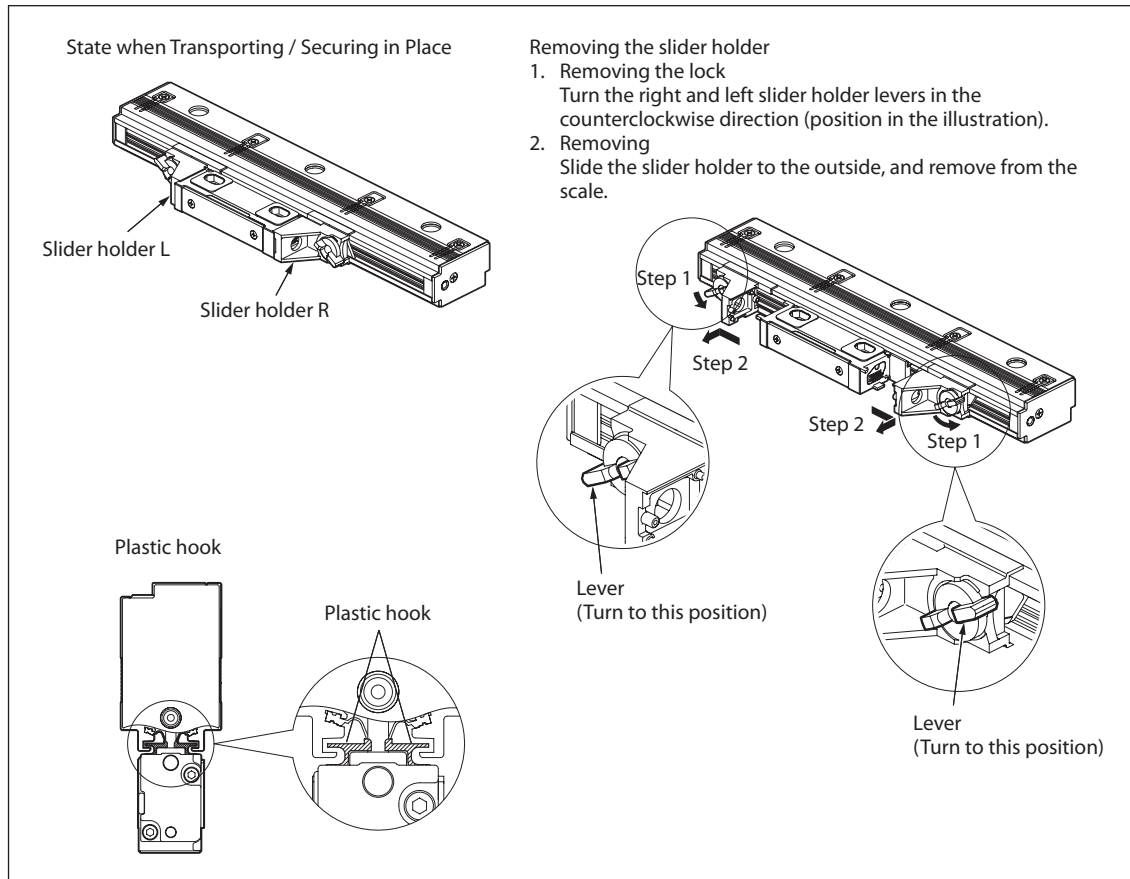

Fig. 2-3

- Before installing the scale, check that the alignment of the installation surface (or installation brackets) is within the standards.
- Use a scale installation bracket, where applicable, having a length covering the entire scale length. Even when using divided brackets, be sure to always check that the alignment of the installation brackets is within the standards.
- The rear surface of the scale unit is used as the installation guide.
- Loosely turn the mounting screws first. Determine the alignment and then tighten the screws to fasten the scale. (See Fig. 2-4)

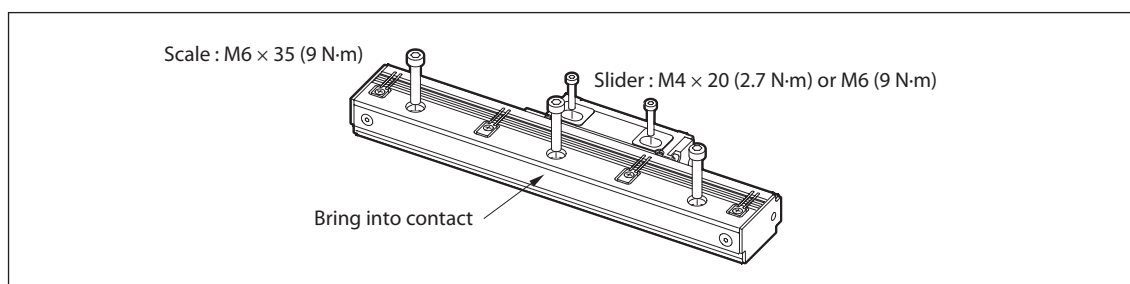

Fig. 2-4

Installation example

Example 1 (recommended): Installation when a stop surface of the scale and slider is made with the bracket

Scale installation accuracy is improved when a stop surface is made. This also simplifies reinstallation of the scale.

1. Check and adjust the scale bracket's parallelism with respect to the machine guide, and then secure in place.
Even when using divided brackets, adjust the parallelism over the entire bracket length as shown in the figure.

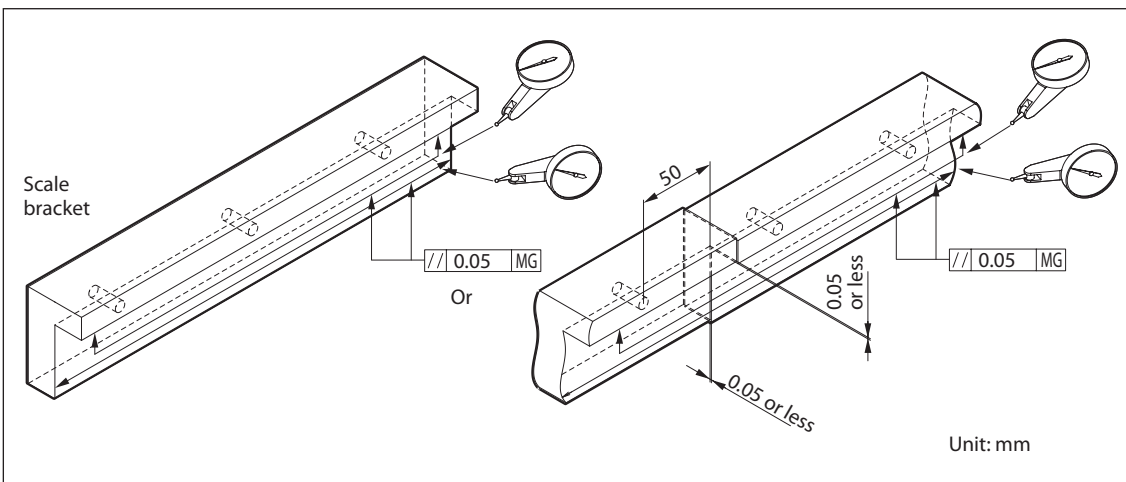

Fig. 2-5

2. Check and adjust the height and parallelism of the slider bracket, and then secure in place.

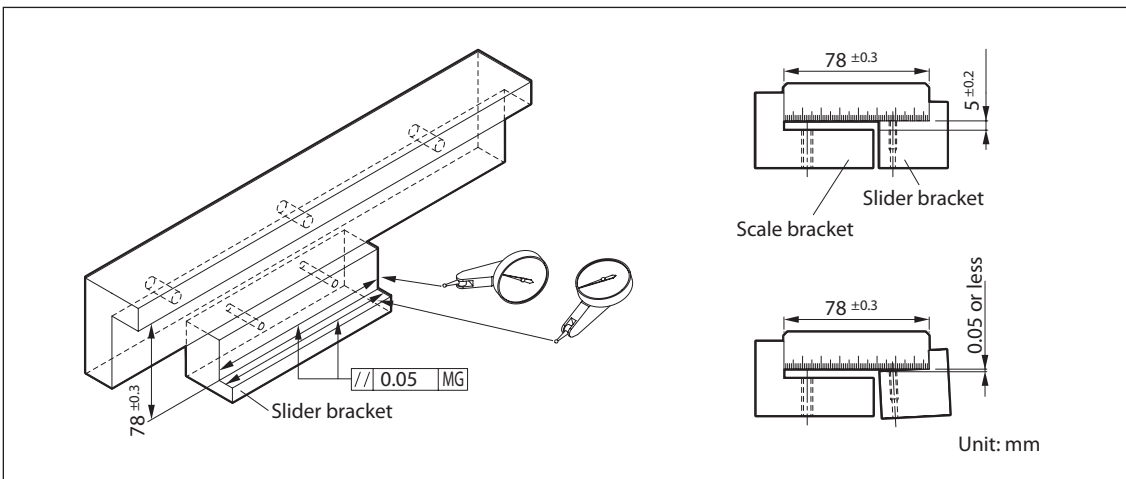

Fig. 2-6

3. Bring the scale into contact with the stop surfaces and install.

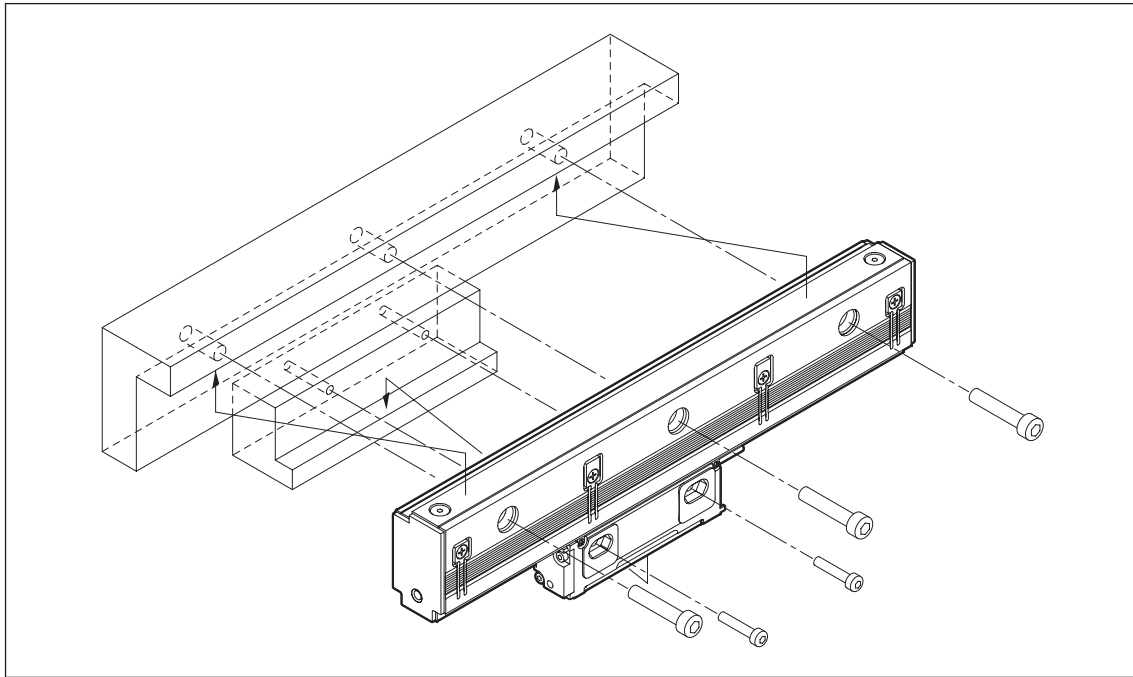

Fig. 2-7

Example 2: Installation when a stop surface of the scale and slider is not made with the bracket

1. Adjust the parallelism of the scale bracket and slider bracket with respect to the machine guide, and then secure in place. Adjust the height and parallelism of the slider bracket with respect to the scale bracket, and then secure in place.

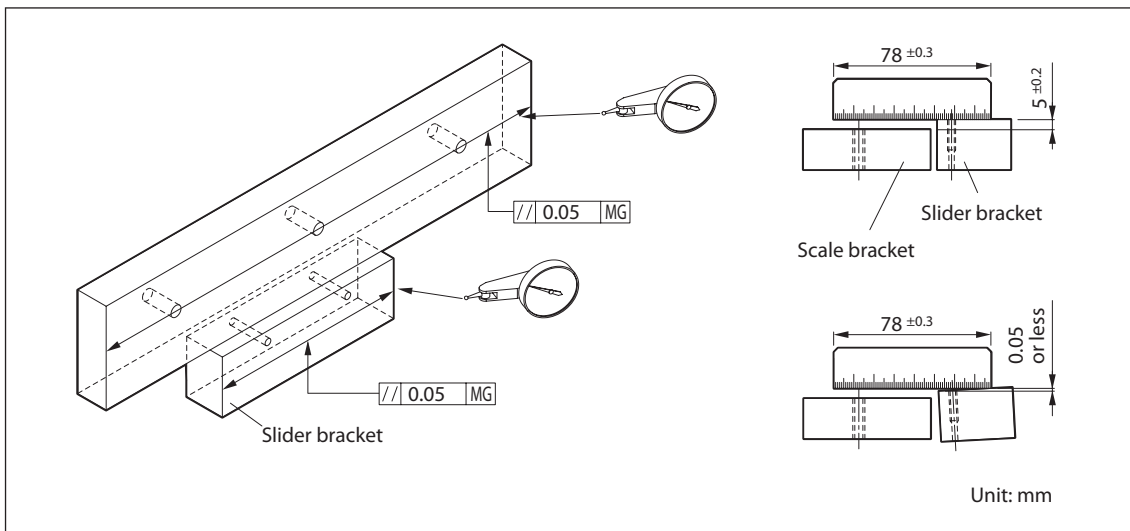

Fig. 2-8

- Adjust the parallelism with respect to the machine guide of the scale rear while measuring the scale rear with a dial gauge. Tighten the set screws.

<Measurement method>

Measure near the installation hole positions at the scale unit rear.

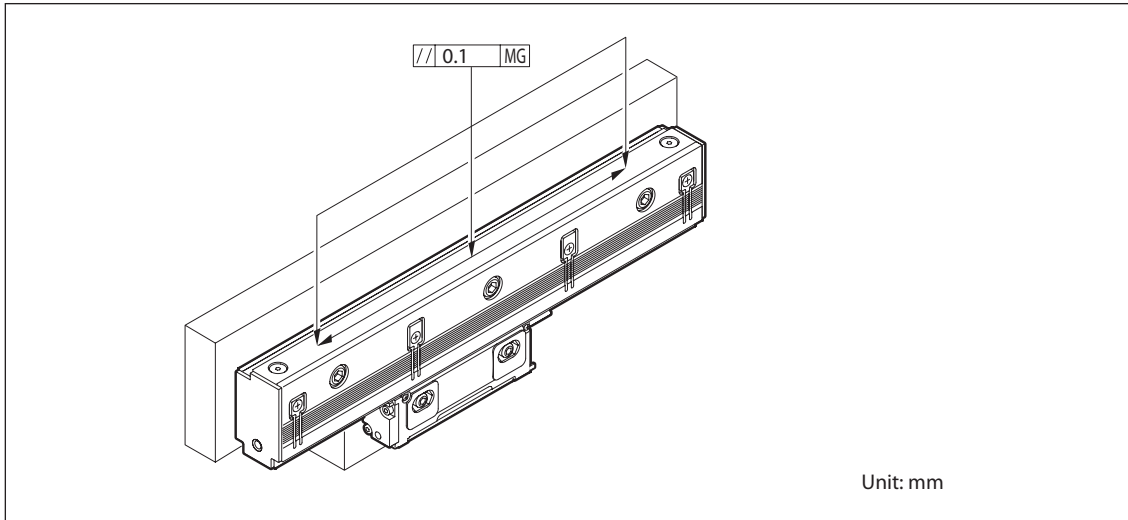

Fig. 2-9

- Insert the supplied spacer ($t = 1.0 \text{ mm}$) in the space between the scale and slider, and then adjust the slider position while bringing the slider into contact with the scale.

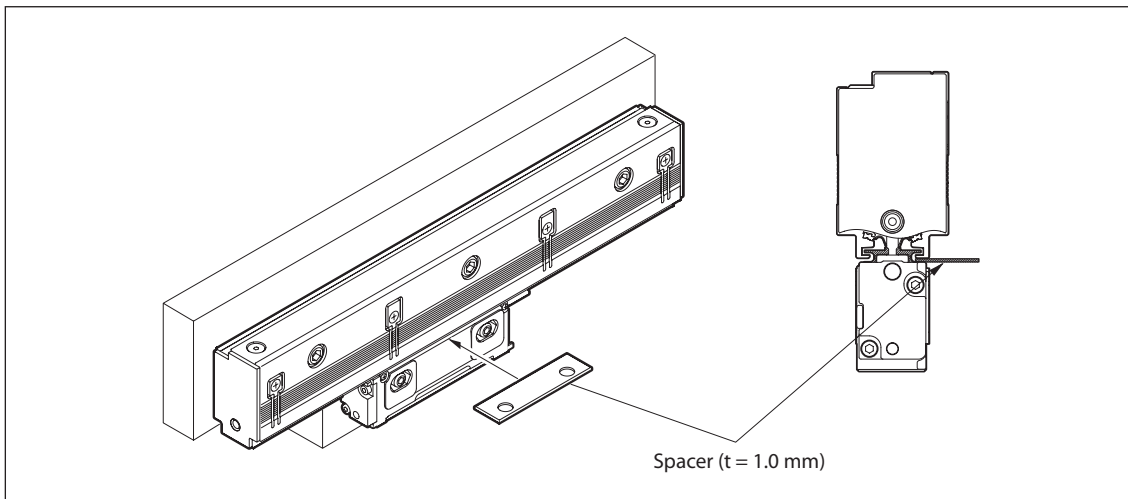

Fig. 2-10

Example 3: Other procedures for slider installation

Install according to your intended application.

Pattern 1

The M4 hex. socket-head cap screws must be supplied by the customer.

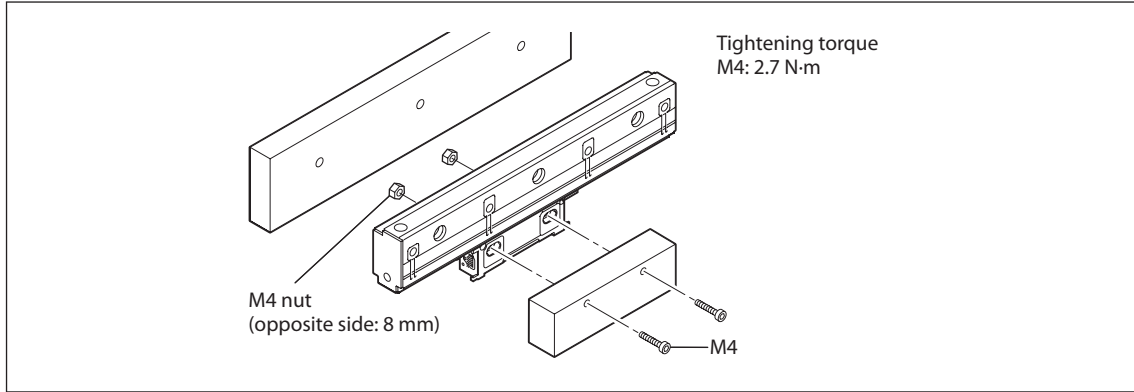

Pattern 2

Installing the rubber bushing on the M4 nut enables installation without the nut falling off.
The M4 hex. socket-head cap screws must be supplied by the customer.

Note

Because the nut position is limited by the rubber bushing, pay careful attention to the tolerance of the slider mounting holes.

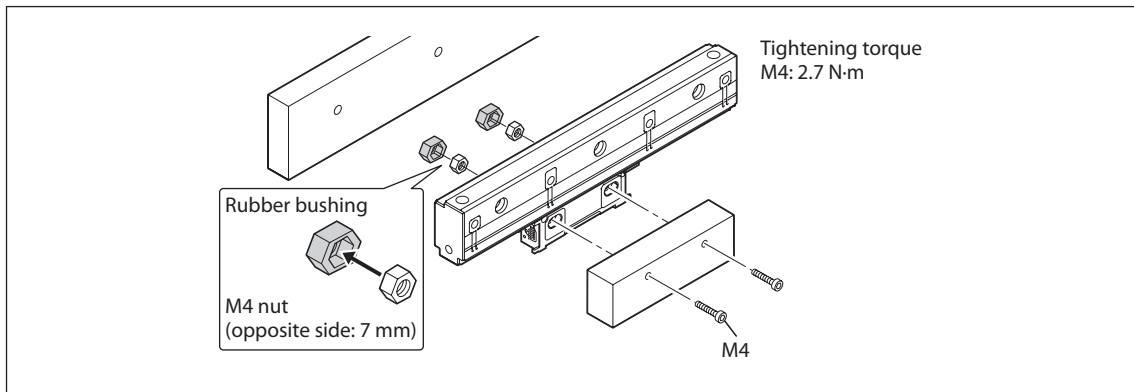

Pattern 3

The M6 hex. socket-head cap screws must be supplied by the customer.

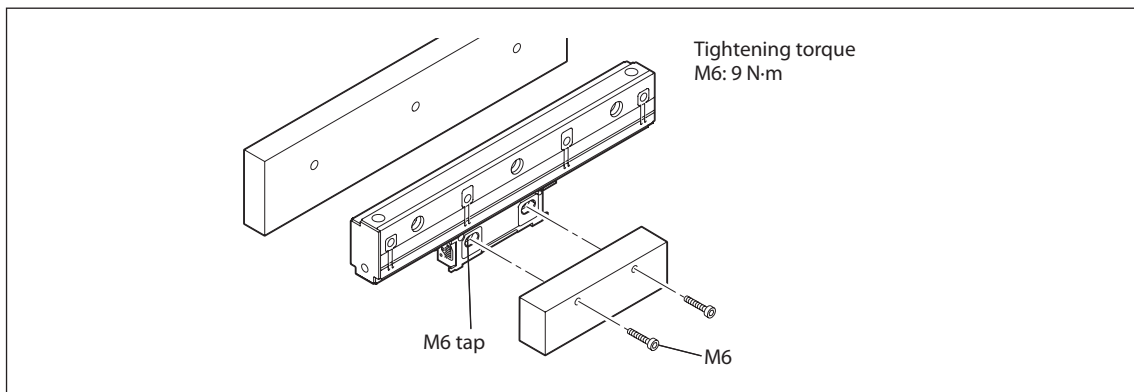

3. Scale (SR87) and Connection Cable

- Steel bars are used for the scale case to achieve a high rigidity.
The magnetic shielding effect of the scale is maintained by installing steel plates inside the scale.
- The scale unit and connection cable are separated by the connector of the scale slider unit.
The cable extension direction to the right or left is selected when ordering.
- All models use direct output.
- This absolute scale incorporates a slider with built-in interpolation circuit having resolutions of 0.01, 0.05, 0.1, 0.5, and 1.0 μm and is capable of bidirectional serial communication that complies with the absolute serial communication specifications of controller companies.

3-1. Scale (SR87)

3-1-1. Output Signal

When the slider is moved in the direction of the arrow, the signal is addition when the polarity is “positive,” and it is subtraction when the polarity is “negative.” The polarity is selected when ordering.

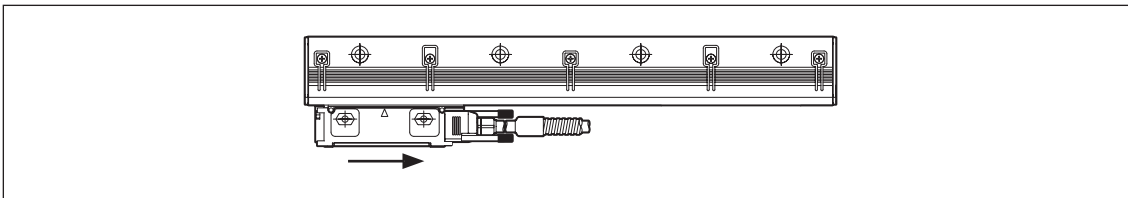

Fig. 3-1

This scale uses absolute serial bidirectional communication protocol for conducting data communication with controllers. For information on supported company protocols, contact your Magnescale Co., Ltd. sales representative.

Communication circuit side

When connecting to a controller, be sure to follow the connection procedure of the controller manufacturer.

3-1-2. Power Supply

Use a power supply that satisfies the specifications below.

Use of a power supply with a short-circuit protection device is recommended.

	SR87
Supply voltage	4.75 - 5.25 V DC
Consumption current	200 mA or less
Inrush current	2 A or less *
Ripple voltage	50 mVp-p or less

*: When the power supply rise time is 10 ms.

Note

Do not turn on the power before installing the scale.

The scale begins functioning normally approximately 0.6 seconds after the power is turned on.

Also, a signal may be output momentarily when the power is turned on or off, and this signal can cause the entire system to malfunction. To prevent this, be sure to follow the proper power-on and power-off procedures.

Power-on procedure

1. Turn on the power for the scale.
2. Turn on the power for the receiving device.

Power-off procedure

1. Turn off the receiving device.
2. Turn off the scale.

3-2. Connection Cable (CH33 / CH34)

Note

Be sure to use CH33 / CH34 to satisfy safety standards.

The CH33 has a cable with unterminated ends and a cable with connectors compatible with various controller manufacturers.

Connecting a signal checker (sold separately) to the CH34 enables checking of the scale signals after the scale is installed. For details about the signal checker, please contact your local Magnescale dealer or sales representative.

Before making any inquiries, find the specific model name from the correspondence table below.

CH33 / CH34 Controller Manufacturer Correspondence Table

(Short form of company names)

	CH33	CH34
Unterminated end	○	×
FANUC	○	◎
Mitsubishi Electric	○	◎
Yaskawa Electric	○	×
Panasonic	○	×

◎ : Enables connection with controller, enables connection with signal checker

○ : Enables connection with controller

× : Not available

3-2-1. CH33 / CH34 Signal Specifications

Cable color	Signal Specifications	
	Full duplex	Half duplex
Brown	0 V	0 V
Black	0 V	0 V
Green	+5 V	+5 V
Violet	+5 V	+5 V
Blue	CNT (Note 1)	CNT (Note 1)
Yellow	N.C. (Note 2)	N.C. (Note 2)
Orange	SD	N.C. (Note 2)
Gray	-SD	N.C. (Note 2)
Red	RQ	SD/RQ
White	-RQ	-SD/-RQ

(Note 1) If using a CH33 cable with unterminated ends, be sure that the cable is disconnected and insulated within the connector. Connecting the cable can damage the scale.

(Note 2) N.C.: If using a CH33 cable with unterminated ends, be sure that the cable is disconnected and insulated within the connector. Connection is not necessary.

There are always two cables each for +5 V and 0 V, and so be sure to connect these cables in pairs. If only one cable is connected, the scale may not operate due to the voltage drop in the cable.

■ Securing the connector

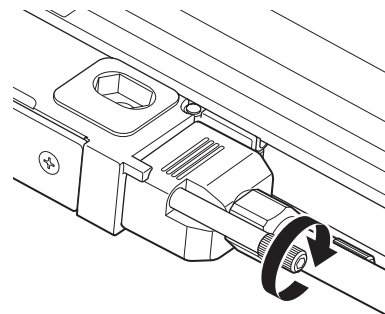

Firmly tighten the set screw of the connector at 0.36 N·m.

4. Air Purge

In the standard configuration, an M5 tap hole for air purging is provided in the end cover section of both scale ends.

Air can be injected into the scale unit to reduce the effects of the environments shown below.

The actual effects, however, will vary depending on operating conditions. Therefore, be sure to fully check the effects before using air purge.

- Use in dusty area
- Use in locations close to coolants

Air Tube Route and Device Configuration

Prepare the devices as shown in the figure below, and air is injected into the scale by connecting the air tubes.

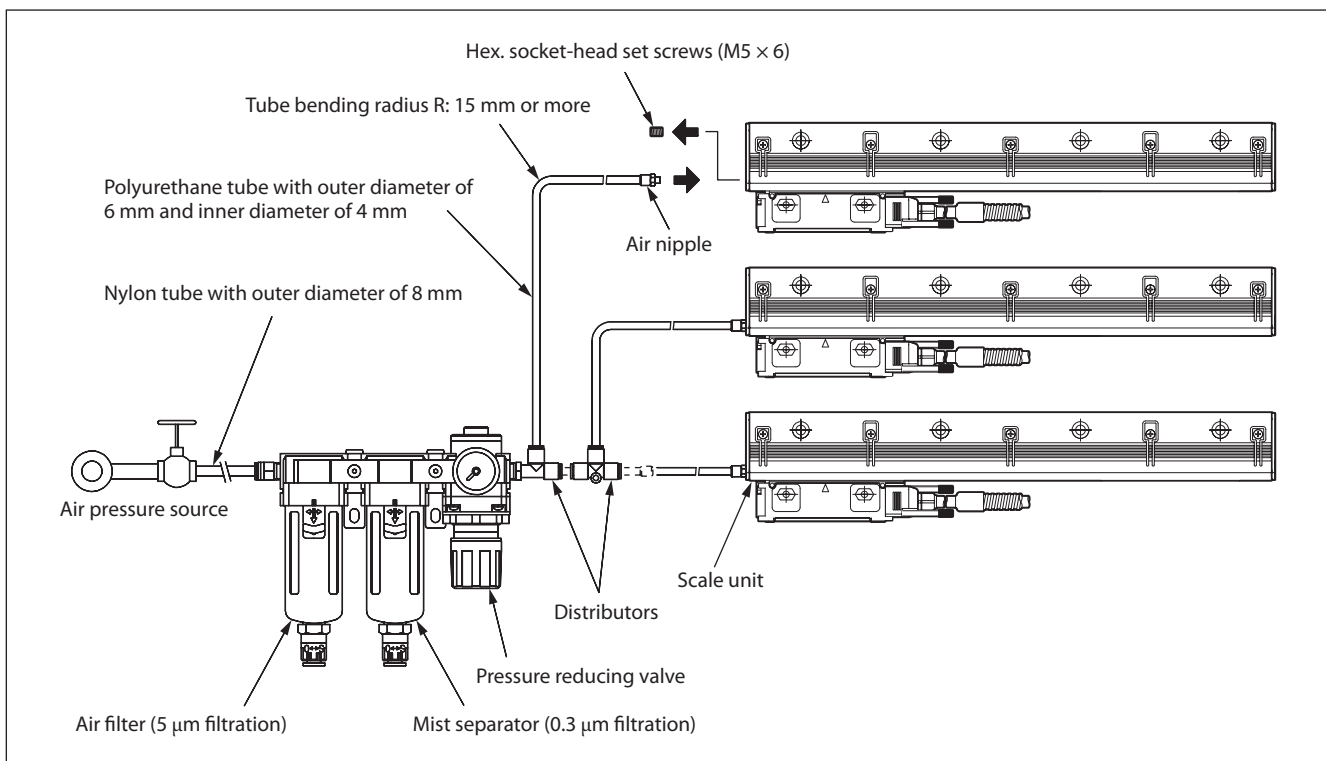

Fig. 4-1

The customer must obtain the air supply unit and input/output air tubes. The recommended air supply unit specifications and main components are shown in the table below.

Specifications

Guaranteed pressure resistance	1.5 MPa
Maximum operating pressure	1020 kPa
Minimum operating pressure	20 kPa
Pressure setting range	20 - 200 kPa
Operating temperature and operating fluid temperature	-5 to 60 °C (no freezing allowed)
Filtration	Air filter: 5 µm Mist separator: 0.3 µm
Pressure gauge connection port	2 × Rc (PT) 1/8
Tube connection port	Input side: Tube outer diameter of 8 mm (1 location), Output side: Tube outer diameter of 6 mm (3 locations)
Auto drain differential pressure	150 - 1020 kPa

Main comsents

Manufacturer	Model	Name	Quantity
SMC Corporation	AF3000-02C	Air filter	1
SMC Corporation	AFM3000-02C	Mist separator	1
SMC Corporation	AR3000-02G-1	Regulator with 200 kPa pressure gauge	1
SMC Corporation	Y30L	Spacer assembly with L-type bracket	2
SMC Corporation	KQ2S06-M5	Air nipple	1

Note

The air filter and mist separator should incorporate a float-type auto drain (NC) mechanism. Use a drain tube with a diameter of at least 4 mm and length of 5 m or less. Set the tubes so that there is no rising.

Tube Layout Notes

Tube arrangement

Use tubes with a bending radius of at least 15 mm and make sure that there are no sharp bends. Also, if the tubes are laid parallel within the ducts for the electrical wiring or hydraulic tubes, be careful that the tubes are not crushed by the movement of the ducts.

Tube length

To inject air simultaneously into multiple scales, make the tubes the same length from the distributor of the air supply unit to each scale so that the injection air pressure is uniform for each scale.

Pressure setting and tube length for pressure reducing valve

If the air injection pressure for each scale is around 20 ± 10 kPa, the air in the scale can be maintained at a low humidity. However, setting the air injection pressure only via the pressure reducing valve will not result in an air injection pressure of 20 ± 10 kPa due to pressure losses stemming from the tube length.

Determine the pressure setting of the pressure reducing valve.

Adjust the air injection pressure to around 20 ± 10 kPa so that the air consumption for each scale becomes 10 to 20 Nℓ/min.

Tube flushing

Flush the tube from the air pressure source to the air supply unit connectors and each scale connector. Flushing cleans the tubes, prevents the embedding of foreign objects in the equipment, and is also useful to check the tubes.

Air pressure source

If a compressor is selected for use, take into consideration the air consumption amount (10 to 20 Nℓ/min per scale). The graph below shows the discharged air amount and rated output as a rough guideline for selecting a compressor. Although the specific graph may vary depending on the compressor model, please use it as a reference.

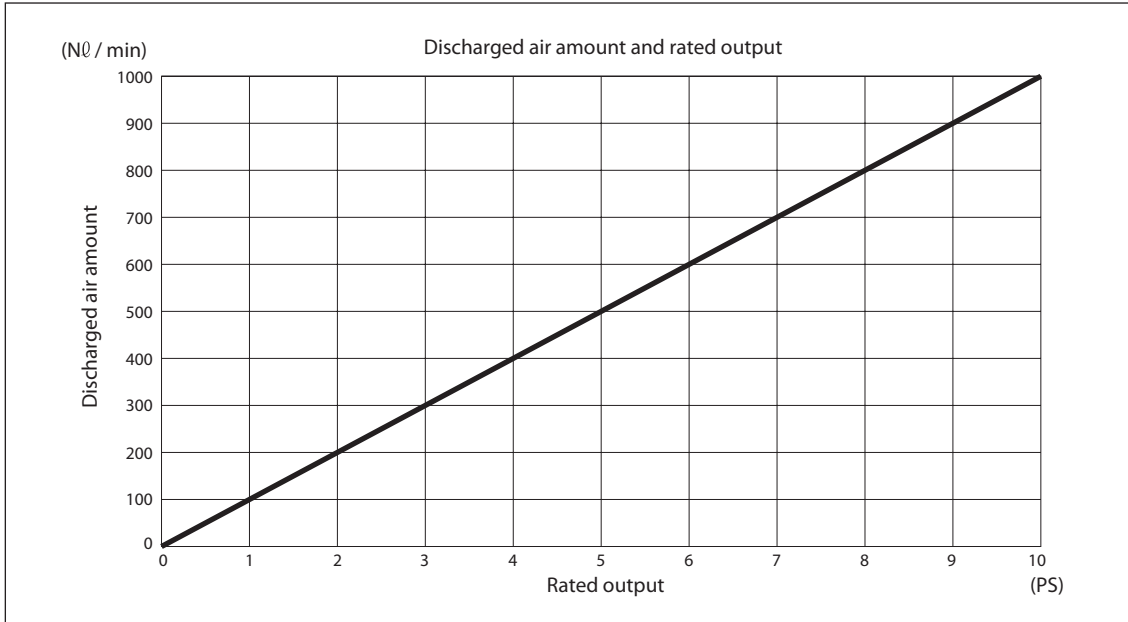

Fig. 4-3

5. Specifications

5-1. Scale

Model name	SR87-XXXR (Cable extending to right), SR87-XXXL (Cable extending to left)
Item	
Effective length (L)	140 to 3040 mm (24 types) 140, 240, 340, 440, 540, 640, 740, 840, 940, 1040, 1140, 1240, 1340, 1440, 1540, 1640, 1740, 1840, 2040, 2240, 2440, 2640, 2840, 3040
Thermal expansion coefficient	$12 \pm 1 \times 10^{-6}/^{\circ}\text{C}$
Output signal	Absolute serial bidirectional signal, compliant with EIA-485 For details, see section 3-1-1, "Output Signal."
Accuracy (at 20 °C) L: Effective length (mm)	$3 + 3L/1000 \mu\text{m-p}$ or $5 + 5L/1000 \mu\text{m-p}$
Resolution	Selectable from 0.01, 0.05, 0.1, 0.5, and 1.0 μm (set at factory shipping)
Power supply voltage	DC 4.75 - 5.25 V (At cable connection end)
Power consumption	200 mA (at 120 Ω terminal) max.
Inrush current	2 A max. (When the power supply rise time is 10 ms)
Maximum response speed	200 m/min (User-selected resolution setting)
Vibration resistance	250 m/s^2 (50 Hz to 2 kHz)
Impact resistance	450 m/s^2 (11 ms)
Protective design grade	IP54 (Air purge not included), IP65 (Air purge included) For details, see section 4, "Air Purge."
Power supply protection	In the case of errors such as a reverse-connected power supply or over-voltage, the internal fuse is cut to protect the power being supplied and wiring.
Operating temperature range	0 to +50°C
Storage temperature range	-20 to +55°C
Mass	Approx. 1.24 kg + 4.00 kg/m
Slider sliding resistance	1 N
Dimensions	See section 6, "Dimensional Diagrams."

The information here is subject to change without notice. When designing machines, please request the latest specifications from your nearest sales representative.

5-2. Connection Cables

Item	Model name	CH33-XXCP CH34-XXCP	CH33-XXCE CH34-XXCE	CH33-XXNP CH34-XXNP	CH33-XXNE CH34-XXNE
Conduit		Included (stainless steel) No conduit is used 100 mm from the slider-side connector and unterminated end		None	
Cable sheath		PVC	Polyurethane	PVC	Polyurethane
Cable length		3, 5, 10, 15 m (standard product), Supports only 1 m units from 1 to 30 m (special-order product)			
Terminal processing		Unterminated end, Connector supporting various controller manufacturers can be attached			
Protective design grade		IP65 (scale-side connector)			
Operating temperature range		0 to +50°C			
Storage temperature range		-20 to +55°C			
Mass		Approx. 0.02 kg + 0.157 kg/m			
Recommended minimum bending radius (when there is repeated bending)		50 mm			
Recommended minimum bending radius (when there is no repeated bending)		Conduit unit: 25 mm, No conduit unit: 20 mm			
Dimensions		See section 6, "Dimensional Diagrams."			

The information here is subject to change without notice. When designing machines, please request the latest specifications from your nearest sales representative.

5-3. Accessories

SR87

M4 × 20 Hex. socket-head cap screws (For slider installation)	2				
M6 × 35 Hex. socket-head cap screws (For scale installation)	3 to 32*			3 to 32*	
* The number of bolts differs depending on the effective length.	Effective length (mm)	No. of bolts	Effective length (mm)	No. of bolts	
	140	3	1340	15	
	240	4	1440	16	
	340	5	1540	17	
	440	6	1640	18	
	540	7	1740	19	
	640	8	1840	20	
	740	9	2040	22	
	840	10	2240	24	
	940	11	2440	26	
	1040	12	2640	28	
	1140	13	2840	30	
	1240	14	3040	32	
M4 Hex. nuts, opposite side: 8 mm (For slider rear surface installation)	2				
M4 Hex. nuts, opposite side: 7 mm (For slider rear surface installation)	2				
Rubber bushing	2				
Spacer (t = 0.1 mm)	2				
Spacer (t = 0.2 mm)	2				
Spacer (t = 1.0 mm)	1				
Accuracy table	1				
Installation Manual	1				

6. Dimensional Diagrams

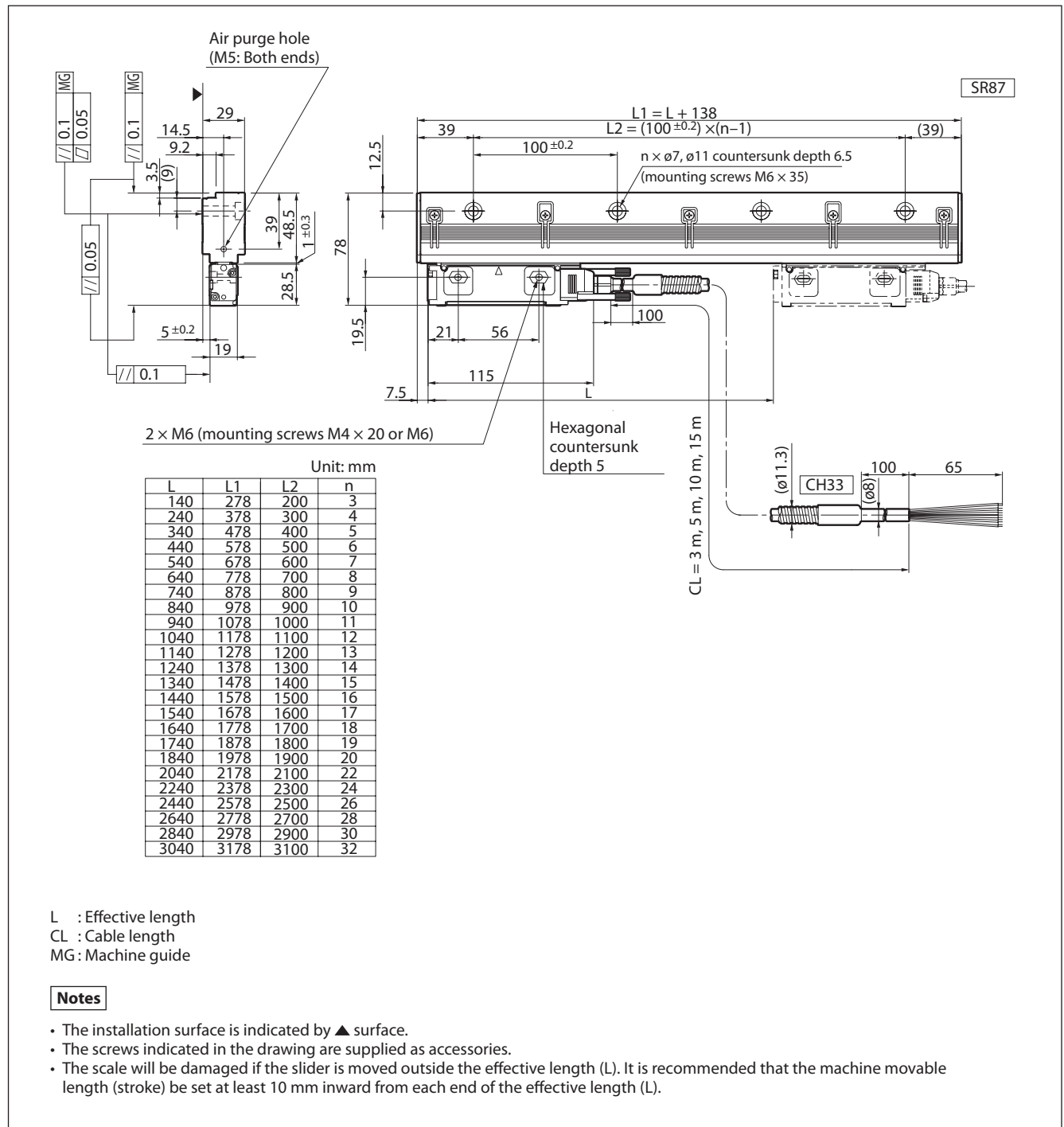

このマニュアルに記載されている事柄の著作権は当社にあり、説明内容は機器購入者の使用を目的としています。したがって、当社の許可なしに無断で複写したり、説明内容（操作、保守など）と異なる目的で本マニュアルを使用することを禁止します。

本手册所记载的内容的版权归属 Magnescale Co., Ltd. 仅供购买本手册中所记载设备的购买者使用。

除操作或维护本手册中所记载设备的用途以外，未经 Magnescale Co., Ltd. 的明确书面许可，严禁复制或使
用本手册的任何内容。

The material contained in this manual consists of information that is the property of Magnescale Co., Ltd. and is intended solely for use by the purchasers of the equipment described in this manual.

Magnescale Co., Ltd. expressly prohibits the duplication of any portion of this manual or the use thereof for any purpose other than the operation or maintenance of the equipment described in this manual without the express written permission of Magnescale Co., Ltd.

Le matériel contenu dans ce manuel consiste en informations qui sont la propriété de Magnescale Co., Ltd. et sont destinées exclusivement à l'usage des acquéreurs de l'équipement décrit dans ce manuel.

Magnescale Co., Ltd. interdit formellement la copie de quelque partie que ce soit de ce manuel ou son emploi pour tout autre but que des opérations ou entretiens de l'équipement à moins d'une permission écrite de Magnescale Co., Ltd.

Die in dieser Anleitung enthaltenen Informationen sind Eigentum von Magnescale Co., Ltd. und sind ausschließlich für den Gebrauch durch den Käufer der in dieser Anleitung beschriebenen Ausrüstung bestimmt.

Magnescale Co., Ltd. untersagt ausdrücklich die Vervielfältigung jeglicher Teile dieser Anleitung oder den Gebrauch derselben für irgendeinen anderen Zweck als die Bedienung oder Wartung der in dieser Anleitung beschriebenen Ausrüstung ohne ausdrückliche schriftliche Erlaubnis von Magnescale Co., Ltd.

日本からの輸出時における注意

本製品(および技術)は輸出令別表第1の16の項(外為令別表16の項)に該当します。キャッチオール規制による経済産業省の許可要否につきましては、輸出者様にてご確認ください。

For foreign customers

Note: This product (or technology) may be restricted by the government in your country. Please make sure that end-use, end user and country of destination of this product do not violate your local government regulation.

Magnescale Co., Ltd.

Shinagawa Intercity Tower A-18F, 2-15-1, Konan, Minato-ku, Tokyo 108-6018, Japan